

WATER QUALITY FOR INDUSTRIAL APPLICATION USING CLOUD COMPUTING WITH IOT ENVIRONMENT

¹P.Avinash, ²Dr. A.Nagarjuna Reddy, ³Dr.MD.Nazmoddin,⁴Dr.V.Anantha Krishna

^{1,2,3,4} Professors, Department of Computer Science and Engineering
^{1,2,3,4} Sridevi Women's Engineering College Telangana, Hyderabad India
¹avinashjntuh@gmail.com, ²anr304@gmail.com,
³najmuddinmohd4u@gmail.com, ⁴krishnaanthav@gmail.com

Abstract - Now a day's water get polluted by several resources and analyzing its quality is a biggest deal for globalization to tackle this major problem need to monitor continuously the quality of the water, so that first need get the water parameter like its Temperature ,PH , Turbidity and Level of the water in which rate of water get flush out from industry . By manually monitoring the water quality is very time consuming as well as its complicated to get water parameter in real time. To overcome this testing equipments are going to be place in the reservoir as the variations occurs in these parameter will get to know the presence of pollutants. In this paper a new approach has been adopted to analyze the quality of the water under IoT environment. The proposed system contains data acquisitions node, controlling unit as ARM, base station and monitoring unit, where all these units are connected to each other .Data can be collected from various sensor and each sensors has its own way to read the data about physical phenomenon ,so necessity to write diverse code for each sensor for data collection procedures. Meanwhile to control and to do some preprocessing work MCU unit has been adopted, after data collection from various sensor such as its Temperature, Turbidity, PH, etc at base station is sent to display on monitoring node and also compared with standard values .By continually monitoring water quality people get awareness locality water condition so we can minimize its critical effect on human life ,fired, animals etc with high frequency.

Key Words: Internet of things (IoT), WSN, MCU, Communication standards, Temperature sensor, level sensor, Turbidity sensor.

1. INTRODUCTION

At present situation we all are facing global warming the main reason for global warming is pollution which may be water pollution or environment pollution this critical issue can be avoided by protecting environment. Meanwhile water pollution is major task which we are numerously facing now

days. Water get polluted due to industrial wastages, or due disaster or by humans. This paper presented different technologies, parameters to analyze the water quality. In which IoT is being considered as a technological invention which provides a worldwide network to interconnect objects and its advancement depends on a various new technologies, like WSN, cloud computing and information sensing [4]. As given below figure 1 IoT architecture consist three layer in which combined with sensing objects, integration part and number of sensor nodes, modeling techniques, communication protocols, security and privacy[9].

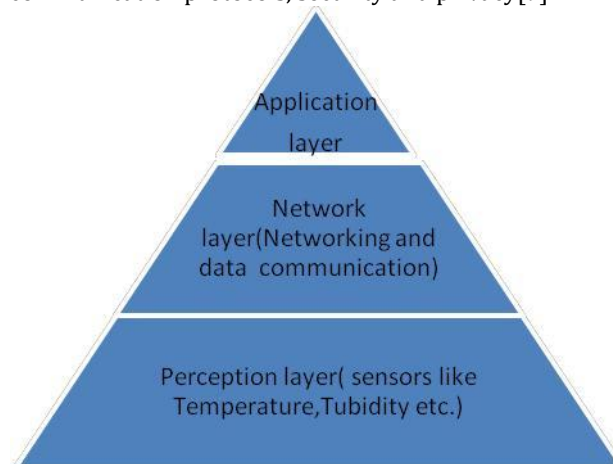

Figure 1 IoT Architecture.

Wireless sensor networks (WSN) are widely used in various kinds of application to sense and collect data about physical things for get better understanding. Monitoring system is depends on wireless sensor conception which contains sensor nodes, clustering ,sink node and has a limited power source to conquer this they were extended network lifetime by dynamic power management and scheduled switching mode protocol[11]. End node of IoT frequently transmit the sensed data from cluster node to server ,whereas to analyze redundant data ,duplicate reading and how efficiently data can aquire,transmite , store among several source node is remain a difficult task. To get better solution for this Shancang Li *et.al* [4] studied compressed sensing (CS)

theory to tackle with redundant data in which data or signals sampled and reconstructed precisely with fewer samples. Li Wang *et.al* [2] stated data cleaning algorithm to prevent redundant data as well to achieve integrity in actual. In [10], Siyuan Chen *et.al* effectively investigated the capacity of data collection in WSNs is many to one data collection to improve node failure. Due to physical property of sensor like the type of sensor signal type ,its sampling rate are limits for universal data acquisition .By developing new design method for multi sensor data obtaining interface device for plug and play for different types of sensor ,IEEE1451 interface protocol will automatically enhance the network to get data from sensor[1]. So this design adopted MCU controller has advantages of low cost, easy implement with high performance

2. RELATED WORK AND METHODOLOGY

Monitoring the quality of the water resources is essential need to avoid critical effect on human life filed, which causes dieses through contaminated water. Water gets polluted in many ways like industrial wastages, due to disaster, or human being. So that people need to get awareness locality water condition. Various technologies, theories, as well as algorithms have been presented . Fabiano Salvadori *et.al* [11] extensively studied and proposed dynamic power management to increase WSNs life time. The designed system was adopted two hardware topologies Intelligent sensor module i.e. IMS and Remote data acquisition unit (RDAUs) for data storing, acquiring and transmitting. Dynamic power management with scheduled switching mode used to switch a sensor node to sleep mode after transmitting a data packet. Li Wang *et.al* [2] presented five layer system architecture to integrated WSN and RFID technologies for interactive action for manufacturing atmosphere, in that they were adopted data cleaning algorithm to prevent redundant data which will cause due to duplicate reading and due to time delay between each sensor nodes. In Zhou *et.al* [7] defined data fusion framework to deal with massive data. Data fusion framework comprises with hypothesis, methods, and algorithms. This crucial tool for data manipulating, managing to increase the efficiency of processing as well as to achieve advanced intelligence in IoT and WSNs.

3. PRAPOSED SYSTEM

For current scenarios monitoring the polluted water resources is essential need to avoid major effect on human life, filed, industrial application ,to mitigate and monitor critical situation from contaminated water we propose a new design which is includes interface device to

collect data effectively from diverse sensor and MCU for controlling the entire operation and for some preprocessing . Thus the performance analysis has been conducted and adequate effects is carried out on water reservoir monitoring for industrial application by detecting the value from temperature sensor, level sensor turbidity sensor, we can minimize the censorious stages for industrial water reservoir monitoring for industrial application using IoT .Water gets polluted in many ways like industrial wastages, due to disaster, or human being. So that people need to get awareness locality water condition. To achieve this prototype block diagram is approached below in figure2.

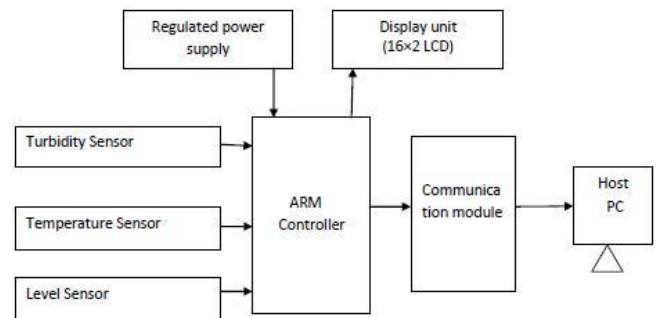

Figure 2 System's hardware block diagram.

Major Parameter Description Used in System's Hardware:

3.1 Interfacing device

Sensor interface device term is applied to a device, which contains number of sensors with an ability of processing, integrating the collected data and then transmit together ether wired based or wireless. Generally device has restriction about sensor data type, its sampling rate, and make device smart each sensor need complicate program code to sense data for physical phenomenon. In a proposed hardware system ARM is used as a core controller in data acquisition interface device and it is 32-bit controller with three stage pipeline (Fetch, decode and execute), in which von-Neumann architecture is adopted. This controller is easy to implement, low power consumption and has a low price.

3.2 Display unit

LCD (Liquid crystal display) unit is widely used in many more application. LCDs are more emerging in nature which are easily programmable and no limitation to display special symbols & characters (unlike in seven segments), animations and so on. A 16x2 LCD means there are 2 lines in that it can display 16 characters per line. In LCD display unit each character is displayed in 5x7 pixel matrix. LCD contains two registers i.e. Command and Data. Command has to be given to initialize LCD as well to do some predefine work like clearing, setting cursor on screen, controlling etc. displayed data has to store in data register.



Figure 3 LCD display unit.

3.1 Level sensor

Magnetic float sensor like on / off switch which helps to sense the level of water present in the overhead tank or sump. The tank, the switch gets activated by the magnet in the float, thereby the signal which is obtained from the sensors have a permanent magnet in the float. The Switch is present in the white stem of the sensor. As the float rises or falls with level of water in sensors is used along with the water level indicator.

Specifications: Level measurement type - High/low. Switching capacity - 10W
Switching voltage - 0.5
Amp.max. Switching voltage - 25v DC max. Cable - two cores



Figure 4 Magnetic float sensor.

3.2 Turbidity sensor

Turbidity sensor (TSD-10 Module) is use detect and measure the suspended particles i.e. turbidity in water, due to this it will effect on Fields, living organism etc. suspended particles can be measured by using an optical transistor and optical diodes, an optical sensor measures the amount of light coming from the source of the light to the light receiver, in order to calculate water turbidity.

Specifications:

Module Number - TSD-10.
Related voltage - DC 5v.
Voltage difference - $3.0 \pm 10\%$
Related current- max 30mA



Figure 5 Turbidity sensor.

4. WATERRESERVOIRMONITORING HARDWARE PHYSICAL MAP WITH EXPERIMENTAL RESULT:



Figure 6 Displaying Turbidity sensor and level sensor values.



Figure 7 Hardware setup .

5. CONCLUSION

Now a day's water get polluted by many ways like human being, disaster or may be due industry so analyzing the quality of contaminated water is crucial part for industrial application, home, environment application etc. By monitoring the quality of the water resources is to avoid major effect on both human lives as well as on filed, which causes dieses through contaminated water. So that people need to get awareness locality water condition. To fix this critical issues the system has been proposed for water reservoir monitoring using IoT under this system MCU is used as a controller to do some specific as well as preprocessing task, data acquisition can be done in parallel way by detecting the for temperatures sensor value ,turbidity sensor and level sensor values. In this way increase the quality of water and reduce its bad impacts.

ACKNOWLEDGEMENT

I would like to thank my guide Prof. Dr. D.S. Bilgi, for being moral support through the period of my project study in BVCOEW, Pune whose help and shared knowledge was the main support to my project.

workflows," *IEEE Transaction Industrial Informatics*. vol. 10, no. 2, pp. 1478–1485, 2014.

REFERENCES

- [1] Qing ping Chi, Hairong Yan, Chuan Zhang, Zhibo Pang, and Li Da Xu, "A Reconfigurable Smart Sensor Interface for Industrial WSN in IoT Environment," *IEEE Transactions on Industrial Informatics*, vol. 10, no. 2, pp.1417-1425, May 2014 .
- [2] L. Wang, L. D. Xu, Z. Bi, and Y. Xu, "Data cleaning for RFID and WSN integration," *IEEE Transactions on Industrial Informatics*, vol. 10, no. 1, pp. 408-418, February 2014.
- [3] Y. Fan, Y. Yin, L. Xu, Y. Zeng, and F. Wu, "IoT based smart rehabilitation system," *IEEE Transaction on Industrial Informatics*, vol. 10, no. 2, pp. 1568–1577, 2014.
- [4] S. Li, L. Da Xu, and X. Wang, "Compressed sensing signal and data acquisition in wireless sensor networks and internet of things," *IEEE Transaction on Industrial Informatics*, vol. 9, no. 4, pp. 2177–2186, Nov. 2013.
- [5] M. T. Lazarescu, "Design of a WSN platform for long-term environmental monitoring for IoT applications," *IEEE Journal On Emerging And Selected Topics In Circuits And Systems*, Vol. 3, No. 1, pp. 45-55, March 2013.
- [6] S. D. T. Kelly, N. Suryadevara, and S. C. Mukhopadhyay, "Towards the Implementation of IoT for environmental condition monitoring in homes," *IEEE Sensors Journal*. vol. 13, no. 10, pp. 3846–3853, Oct. 2013.
- [7] J. Zhou et al., "An efficient multidimensional fusion algorithm for IoT data based on partitioning," *Tsinghua Science and Technology*. vol. 18, no. 4, pp. 369-378, Aug. 2013.
- [8] R. Dafali, J. Diguët, and J. Creput, "Self-adaptive network-on-chip interface," *IEEE Embedded System Letters*, vol. 5, no. 4, pp. 73–76, Dec. 2013.
- [9] Z. Bi, L. Xu, and C. Wang, "Internet of Things for enterprise systems of modern manufacturing," *IEEE Transaction Industrial Informatics*, vol. 10, no. 2, pp.1537–1546, 2014.
- [10] S. Chen et al., "Capacity of data collection in arbitrary wireless sensor networks," *IEEE Trans. Parallel Distributed. Systems*. vol. 23, no. 1, pp. 52–60, Jan. 2012.
- [11] F.Salvadori et.al. "Monitoring in industrial system using wireless sensor network with dynamic power management." *IEEE Transactions on Instrumentation and Measurement*, vol. 58, no. 9, pp. 3104-3111, September 2009.
- [12] L. Xu and W. Viriyasitavat, "A novel architecture for requirement-oriented participation decision in service